

# BOOK SHIPPER A GOOD BOX FOR LIBRARIES AND SCHOOLS OR ANYONE WHO HAS TO STORE AND SHIP BOOKS

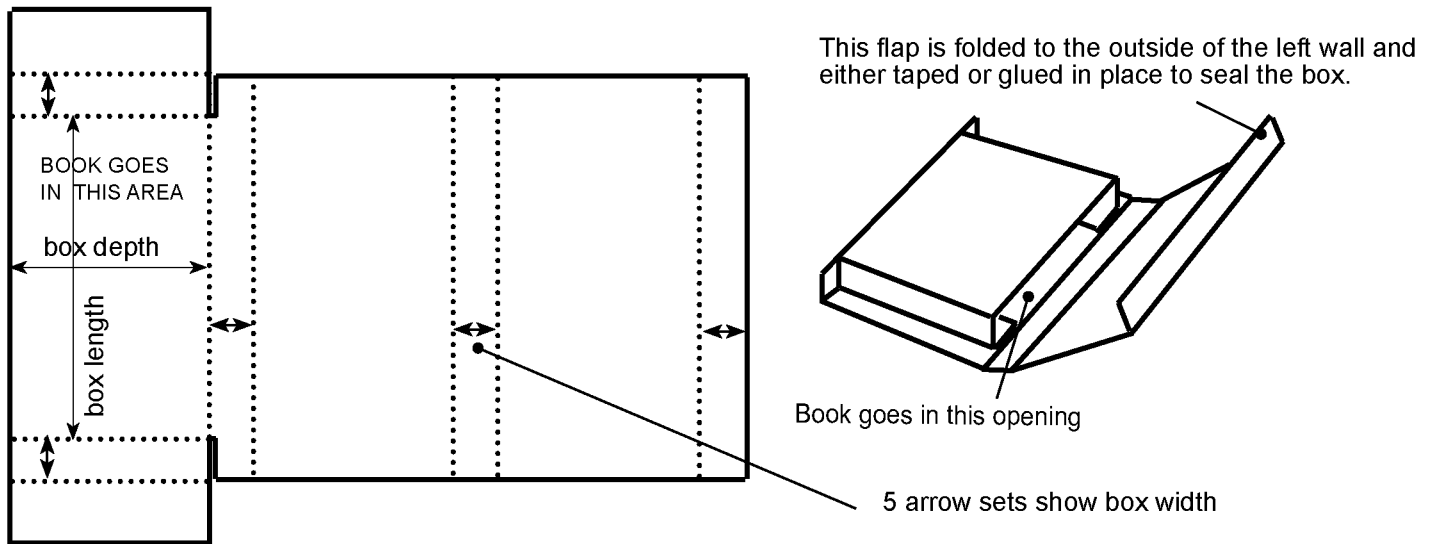

## BOXES FOR BOOKS

- 1 Page 188 of the Thames and Hudson Manual of Book Binding by Arthur W. Johnson shows how to make what he calls a "Solander Box" -- made essentially from wood and hardboard and covered with leather and buckram.
- 2 Page 184 of the above book shows how to make a "Drop-Back Box" of "millboard".
- 3 Instructions for "Hinged Cover and Hinged Side Boxes" are shown starting at page 123 of Books, Boxes and Portfolios by Franz Zeir.
- 4 The Packaging Designer's Book of Patterns by Roth and Wybenga have a number of boxes of the "Clamshell" type made out of (a) cardstock and (b) corrugated cardboard -- see page 384 for a "One Piece Telescope Box" and page 37 for a "Six Cornered Brightwood Style Tray" (a number of variations follow page 37)

**When using corrugated cardboard, be sure to allow the 1/4" for clearance of opposite panels as explained on page 10 -- item 7.**



**Protect your books !!**



Seven elegant book boxes made by Michael Elwell. They are mostly covered in fabric

**ONE-PIECE CLAMSHELL BOXES** -- This box style is often used in museums to store collections of various types. Museums primarily use archival cardstock materials.

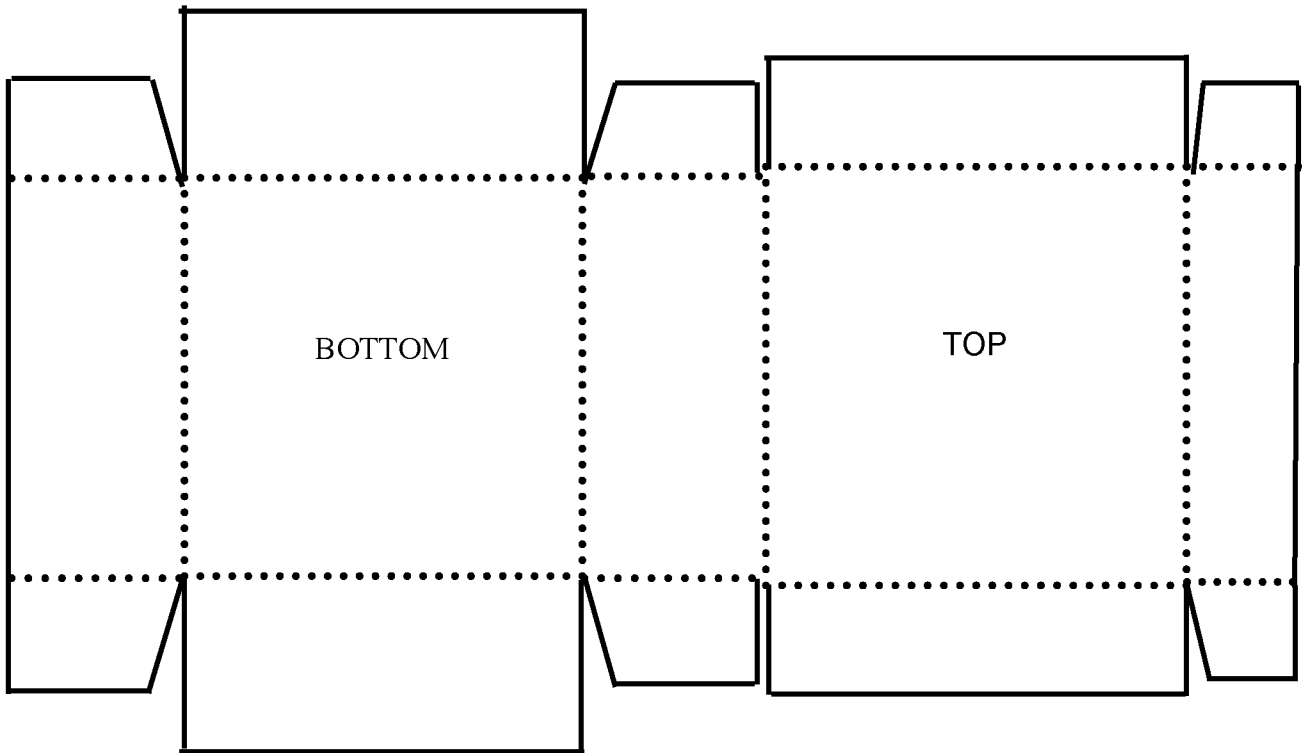

Note the panel marked "TOP" has to be cut a little larger *or* smaller in both length and width than the panel marked "BOTTOM", depending whether the top sides are going to go outside or inside the bottom sides.

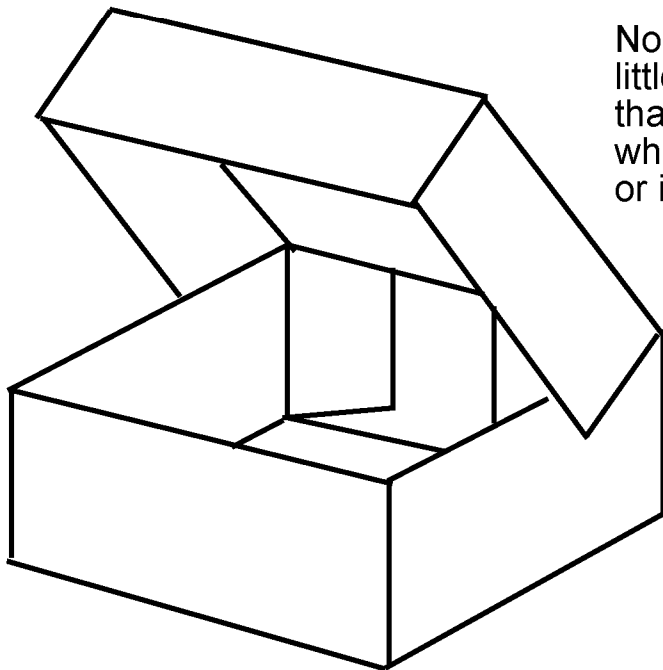

**CLOSED**

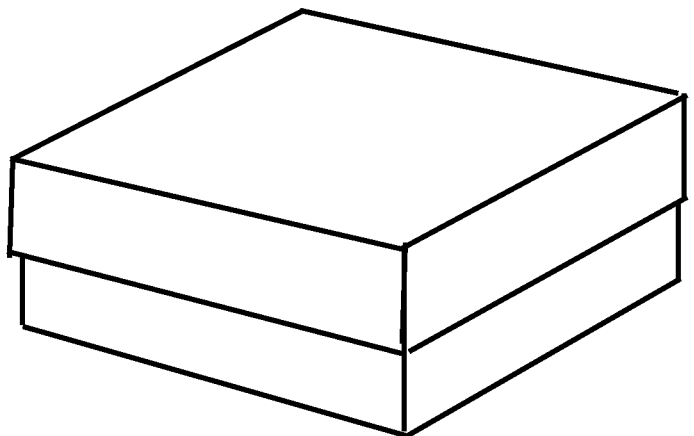

**OPEN**

The flaps on the top of the box can be designed to go inside or outside the box bottom .